



Meaningful Innovation.

WEEE Number: 80133970

INSTRUCTION MANUAL REMOTE CONTROLLER

TECHNICAL DATA

SKU	23743
WORKING VOLTAGE	AAA battery * 2pcs (2.2-3V) (Not Included)
SCREEN OFF DURATION	60S
ICON FLICKING DURATION	5S
S(START) BUTTON ON DURATION	10S
M(MEMORY) BUTTON FLICKING DURATION	3S
CARRIER FREQUENCY	38KHz±2KHz
OPERATION DISTANCE MAX.	15M/49ft (3V)
EMISSION ANGLE	< 30 degree
STANDBY CURRENT	<1.2uA
WORKING CURRENT	<5mA
PEAK CURRENT	<30mA
WORKING TEMP	-20°C~+60°C
STORAGE TEMP	-30°C~+85°C



COMPATIBLE SENSOR

23741, 23742
(PURCHASE SEPARATELY)

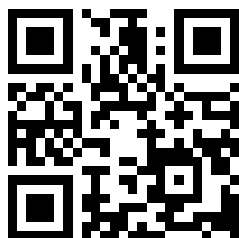

MULTI-LANGUAGE MANUAL QR CODE

Please scan the QR code to access the manual in multiple languages.



FR

Cet appareil, ses accessoires et cordons se recyclent

À DÉPOSER EN MAGASIN



À DÉPOSER EN DÉCHÈTERIE



OU

Points de collecte sur www.quefairedemesdechets.fr
Privilégiez la réparation ou le don de votre appareil !

In case of any query/issue with the product, please reach out to us at: support@v-tac.eu
For More products range, inquiry please contact our distributor or nearest dealers.
V-TAC EUROPE LTD. Bulgaria, Plovdiv 4000, bul.L.Karavelow 9B

INTRODUCTION

Thank you for selecting and buying V-TAC product. V-TAC will serve you the best. Please read these instructions carefully before starting the installation and keep this manual handy for future reference. If you have any another query, please contact our dealer or local vendor from whom you have purchased the product. They are trained and ready to serve you at the best.

WARNING

1. For indoor use only.



This marking indicates that this product should not be disposed of with other household wastes.

DIMENSIONS

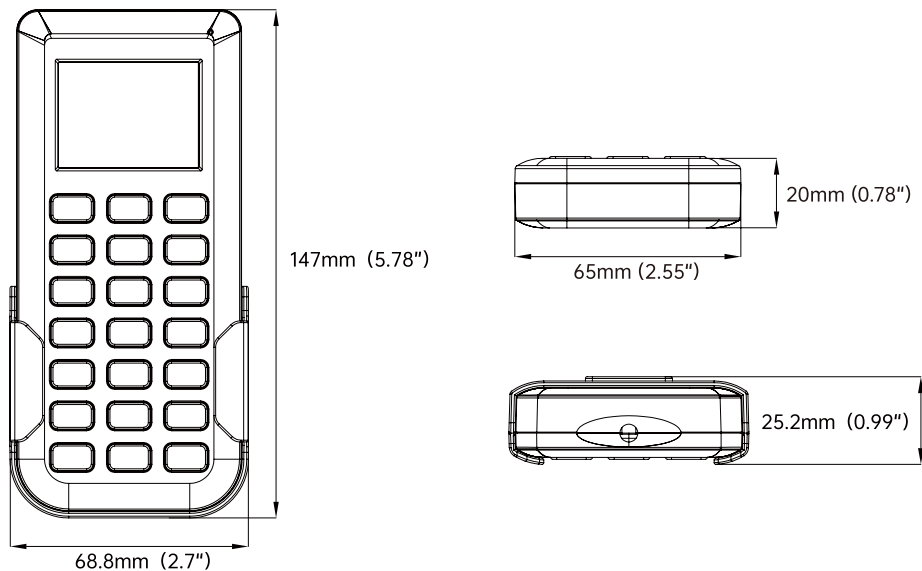

REMOTE INSTRUCTIONS



ON/OFF

1. Turn on or off light
2. Exit sensor mode and enter into ON/OFF mode



Scenes

Press the button to choose in 4 optional scenes; parameters can be saved into each scene and directly activate it.



Apply

Press the button to deliver the saved parameters to target sensors.



Detection range

Press the button, the icon will flick on LCD screen display, then use +/- buttons to choose the wanted parameters.



Hold time

Press the button, the icon will flick on LCD screen display, then use +/- buttons to choose the wanted holdtime.



(Only supporting sensors with CCT tunable feature) Press the button, then icon will flick on LCD screen display, then use +/- buttons to choose from the saved CCT options(2700K, 3500K, 4000K, 5000K, 5700K, 6500K).



This is a reserved button for future updates with unexpected feature.



Press this button, enter into sensor mode and perform the last parameter, press this button and Auto Mode will show on LCD screen display, means commands received successfully.



Press the button to start programming; the S icon will appear on the LCD screen, and disappear if no action within 10S, need to press it again.



Press the button to relatively adjust sensitivity from the sensor according to real Pinstallation height, make sensors working more perfectly in the environment.



Press the button, the icon will flick on LCD screen display, then use +/- buttons to choose the wanted daylight level; the max level is 400lux, --- means diasble, LEN means learning ambient brightness.



Press the button, numbers on LCD screen display gets higher till the wanted one appears.



Press the button, numbers on LCD screen display gets lower till the wanted one appears.



Make parameters according to daylight harvesting conditions, then press this button to activate this function; DH-ON will show on LCD screen display



Press the button to enter into factory settings, means sensor starts to detect motion and turn on light automatically and only keep 5S holdtime then turn off the light.



Press the button to save the parameters, the M icon will appear on the LCD screen, means parameters saved succesfully



Press the button to deliver the last parameters, instead of"START-MEMORY-APPLY"



Press the button, the icon will flick on LCD screen display, then use +/- buttons to choose the wanted standby dim level.



Press the button, the icon will flick on LCD screen display, then use +/- buttons to choose the wanted standby period; the min is 0S, the max is infinite.



Press the button, the icon will flick on LCD screen display, then use +/- buttons to choose wanted brightness level. *In ON/OFF mode, output dimming range is 10%-100%; In SENSOR mode, output dimming range is 60%-100%.



Press the button to quickly perform testing function, keep only 2S ON then OFF, till motion gets detected and turn on light again.

FAQ

1. How to quickly set multiple sensors to perform the same parameters?

Solution A:

- At the first sensor - press AUTO to enter the SENSOR mode, press START to set parameters (detection area, holdtime, daylight threshold, standby dimming level and standby period), press MEMORY to save parameters, and press APPLY to send parameters. You will see light OFF then ON for once as command's received.
- At the other sensors - press AUTO to enter the SENSOR mode and press APPLY to send parameters. You will see light OFF-ON for once as command's received.

Solution B:

- Use the SCENE function if you have preset parameters - Press AUTO to enter the SENSOR mode, choose from the scene options (1, 2, 3, 4), and press SEND. You will see light OFF-ON for once as command's received.

2. In SENSOR mode, how to turn off the sensor function(disable sensor function)?

- When the light is ON, press ON/OFF to turn OFF the light, and press ON/OFF again to turn on the light, don't press any other buttons.
- When the light is OFF, press ON/OFF to turn on the light, don't press any other buttons.

3. How to perform SENSOR mode when sensors are already in ON/OFF mode?

Solution A:

- Press AUTO to enter the SENSOR mode and perform the last parameter setting. The corresponding parameters will be displayed on the LCD screen.

Solution B:

- Press RESET to enter the SENSOR mode and perform factory setting parameters. The corresponding parameters will be displayed on the LCD screen.

4. How to enter and exit TEST mode?

- **Enter:** In any mode, after pressing TEST button, the sensor enters the TEST mode, means keeping the light ON for 2S, turns off the light, lights ON again after detecting motion and keeps 2S then OFF; keep running this way.
 - **Exit:** Press the ON/OFF button to turn off the light and exit the TEST mode directly; Or press the RESET button to exit the TEST mode, enter the SENSOR mode and performing factory
 - **Settings:** Or press the AUTO button to exit the TEST mode, enter the SENSOR mode and performing the last parameter setting.
-

TROUBLESHOOTING

1. This remote control uses infrared signal transmission, please stay pointing at the target sensor and keep controlling distance within 18M while using it.
2. The infrared signal of the remote control might get affected by the strong natural light brightness, and the remote control may not be able to use or the distance become closer; please try to shorten the distance to the sensor or use it when natural brightness fades.
3. After the LCD screen gets dark, it needs to be woken up again (any button can) before use.
4. The remote control is powered by 2pcs AAA batteries. When the words displayed on the LCD screen is incomplete or unclear, it indicates the battery may be dead, which will affect the remote performance. Please replace the battery.

RoHS



UK
CA

